



### Can you remember the meaning of the new words from Topic 1?

Match each word to its definition.

Key word	Meaning
Sustainability	To complete something without help from anyone.
Perseverance	Organisms that grow in water.
Courage	To care for something.
Resilience	The concept of being able to use or do something for a long time without running out of resources or damaging the environment.
Single-handed	To keep trying, even when it might be difficult.
Algae	Doing something that might scare you.
Stewardship	Getting through a difficult time, being strong on the inside and trying your best.

### Search for words!

Find the races and boats in the word search.

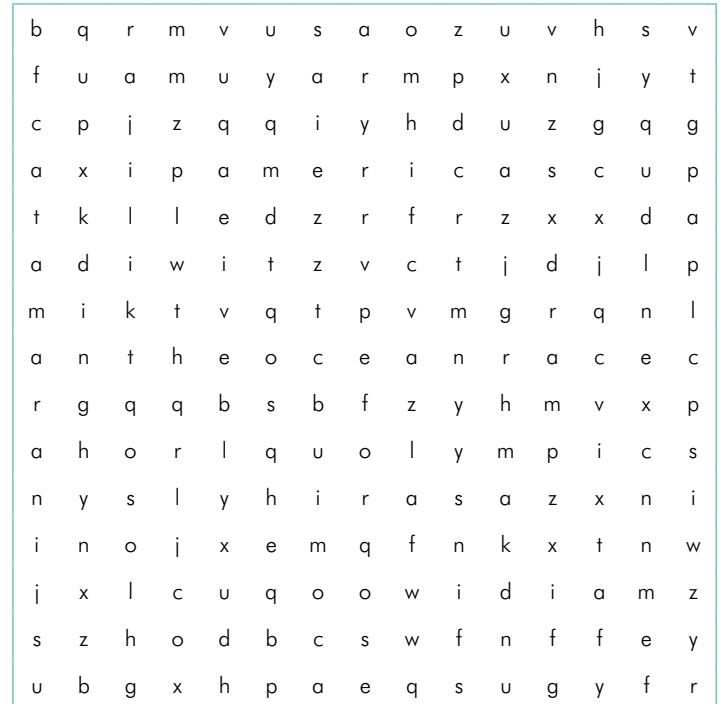

the ocean race  
americas cup

dinghy  
skiff

kitesurfing  
olympics

catamaran  
imoca

### The name game

This is an Optimist. Can you label its parts?

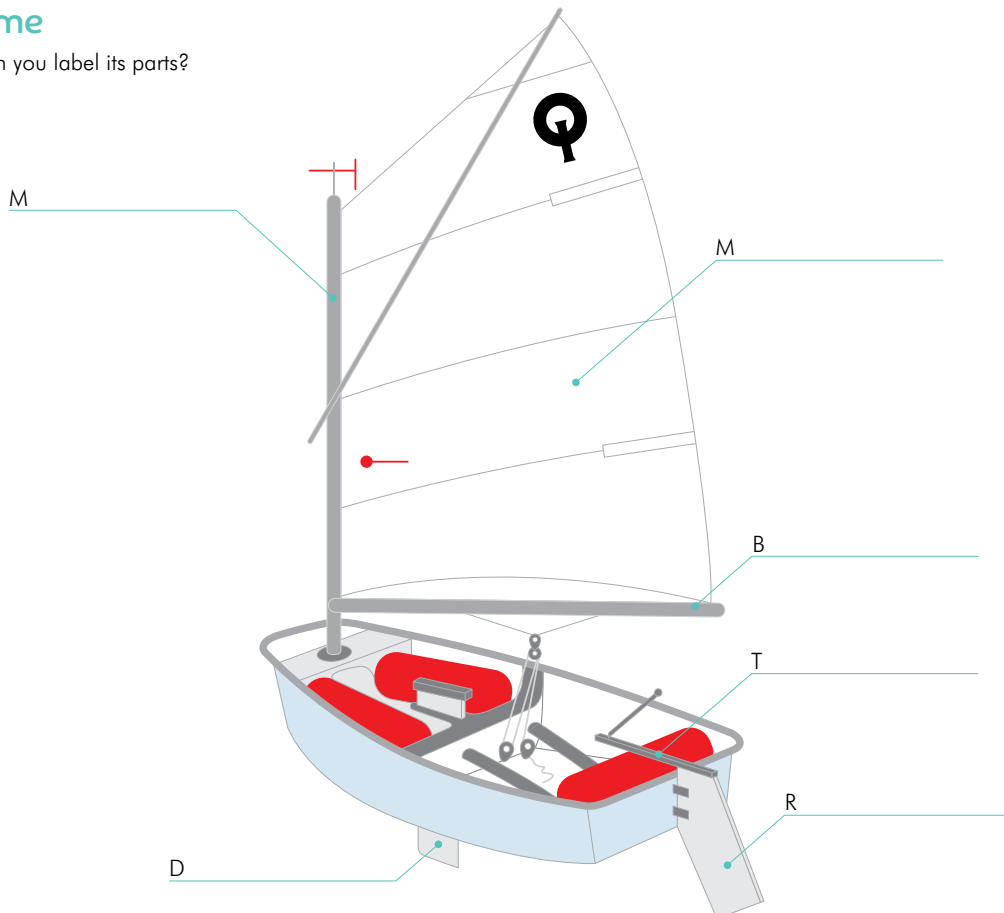



## Quiz time!

Let's see what we remember from Topic 1: Race with World Sailing!  
This is a 2 person team multiple choice quiz. Read each question and decide which answer your team thinks is correct. Check with your instructor for the answers!

### 1. When did World Sailing start?

- a. 1905
- b. 1906
- c. 1907

### 2. What is the name of the goals that aim to solve extreme poverty, fix climate change and fight inequality and injustice?

- a. United Nations Environmental Goals
- b. United Nations Sustainable Development Goals
- c. United Nations Eco-Development Goals

### 3. Which of the races that you learnt about in Topic 1 is the oldest?

- a. The Ocean Race
- b. The Olympic Games
- c. America's Cup

### 4. Which of the races that you learnt about in Topic 1 is the longest?

- a. SailGP
- b. The Ocean Race
- c. America's Cup

### 5. Which of the boats that you learnt about in Topic 1 is the fastest?

- a. F50
- b. IMOCA 60
- c. VO65

---

## Debrief time

My favourite class of boat is the \_\_\_\_\_ because \_\_\_\_\_

I like \_\_\_\_\_ race because \_\_\_\_\_

2 things that I can do to become a more sustainable sailor are:

1. \_\_\_\_\_

2. \_\_\_\_\_



## Can you remember the meaning of the new words from Topic 1?

Use the first letter to complete each word, then match the definitions.

Key word	Meaning
S_____	To complete something without help from anyone.
P_____	Organisms that grow in water.
C_____	To care for something.
R_____	The concept of being able to use or do something for a long time without running out or damaging the environment.
S____-h_____	To keep trying, even when it might be difficult.
A_____	Doing something that might scare you.
S_____	Getting through a difficult time, being strong on the inside and trying your best.

## Search for words!

Find the races and boats in the word search.

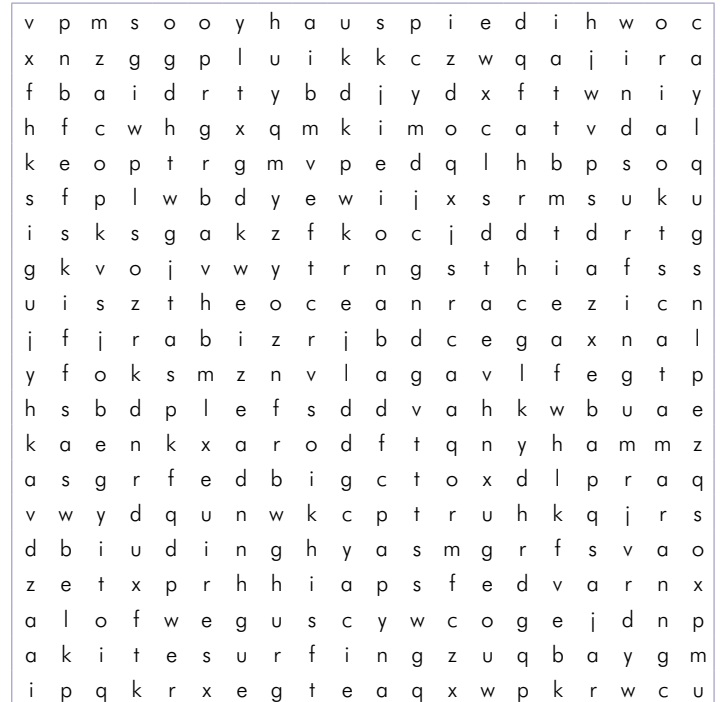

- pwa world tour
- windsurfing
- skiff
- the ocean race
- dinghy
- imoca
- americas cup
- catamaran
- kitesurfing
- olympics

## The name game

This is a Laser, a class of boat raced in the Olympics. Can you label its parts?

Main sail	Hull
Tiller	Rudder
Mast	Daggerboard
Boom	

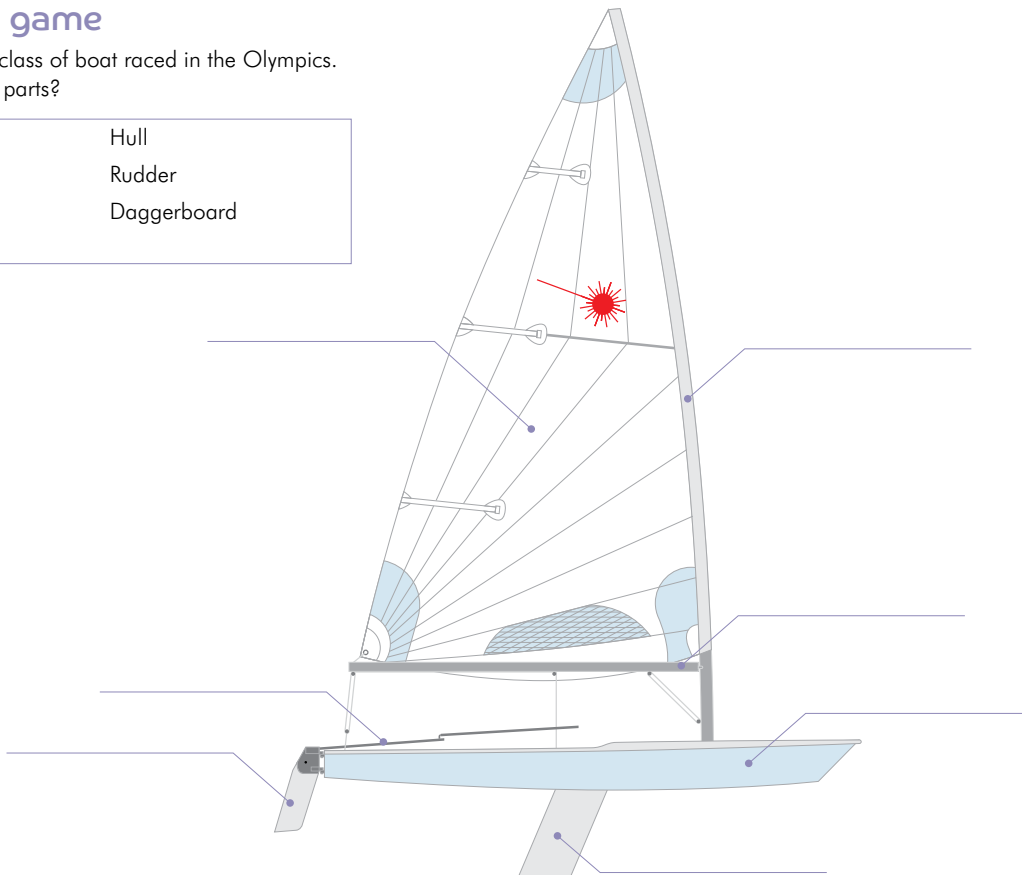



## Quiz time!

Let's see what we remember from Topic 1: Race with World Sailing!  
This is a 2 person team quiz. Read each question and decide on the answer with your teammate. Check with your instructor for the answers!

1. When did World Sailing begin?

- a. 1905
- b. 1906
- c. 1907

2. What is the name of the goals that aim to solve extreme poverty, combat climate change and fight inequality and injustice?

- a. United Nations Environmental Goals
- b. United Nations Sustainable Development Goals
- c. United Nations Eco-Development Goals

3. Which of the races that you learnt about in Topic 1 is the oldest?

- a. The Ocean Race
- b. The Olympic Games
- c. America's Cup

4. Which of the races that you learnt about in Topic 1 is the longest?

- a. SailGP
- b. The Ocean Race
- c. America's Cup

5. Which of the boats that you learnt about in Topic 1 is the fastest?

- a. F50
- b. IMOCA 60
- c. VO65

6. How many sailing events are there in the Olympic Games, where you can win an Olympic medal?

- a. 5
- b. 10
- c. 14

7. How many times has Dee Caffari single-handedly sailed non-stop around the world?

- a. 1
- b. 2
- c. 3

8. Who does Yago Lange sail with in the Olympic Games?

- a. his father
- b. his sister
- c. his brother

9. Bonus question!

List 2 things that make someone a top sailor

---

---

## Debrief time

I'd like to sail a \_\_\_\_\_ because \_\_\_\_\_

I'd like to compete in \_\_\_\_\_ race because \_\_\_\_\_

2 skills I need to develop to become a top sailor are:

1. \_\_\_\_\_ because \_\_\_\_\_

2. \_\_\_\_\_ because \_\_\_\_\_

2 things I can do to become a more sustainable sailor are:

1. \_\_\_\_\_

2. \_\_\_\_\_



### Can you remember the meaning of the new words from Topic 1?

Read each definition and write in the word.

Key word	Meaning
_____	To complete something without help from anyone.
_____	Organisms that grow in water.
_____	To care for something.
_____	The concept of being able to use or do something for a long time without running out or damaging the environment.
_____	To keep trying, even when it might be difficult.
_____	Doing something that might scare you.
_____	Getting through a difficult time, being strong on the inside and trying your best.

### Search for words!

Find the races and boats in the word search.

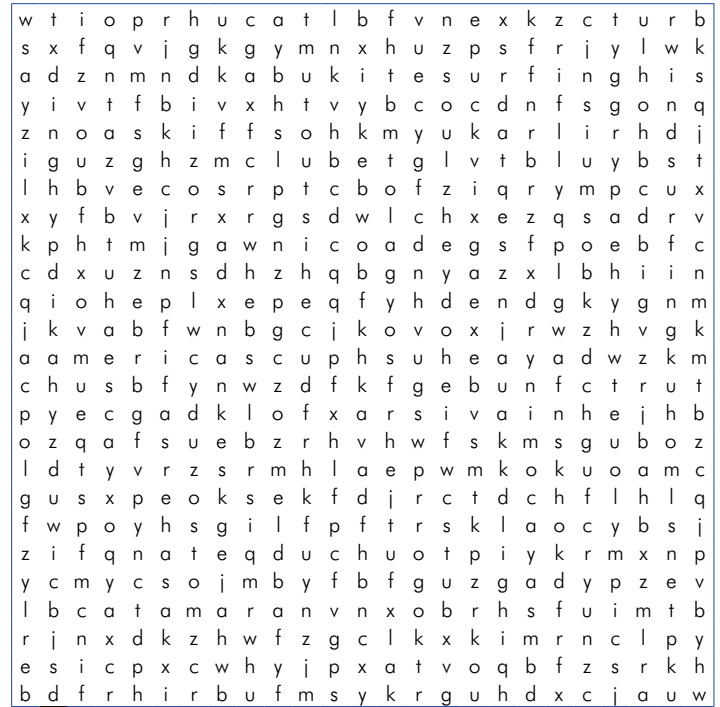

- pwa world tour
- windsurfing
- skiff
- the ocean race
- catamaran
- imoca
- americas cup
- olympics
- kitesurfing
- dinghy

### The name game

Here is a Laser and an iQFOIL.

Can you use the words in the box to label their parts?

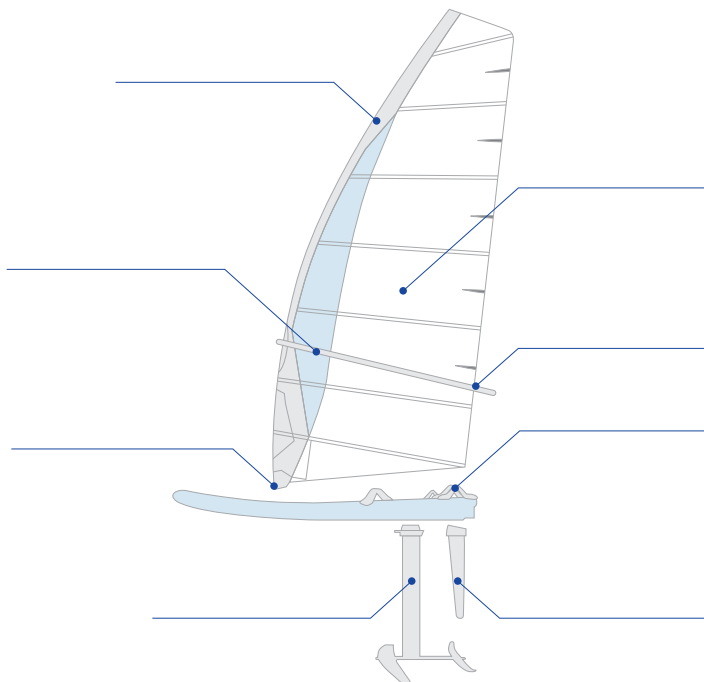

- |           |           |          |      |
|-----------|-----------|----------|------|
| Main sail | Boom      | Out Haul | Foil |
| Mast      | Down Haul | Strap    | Fin  |

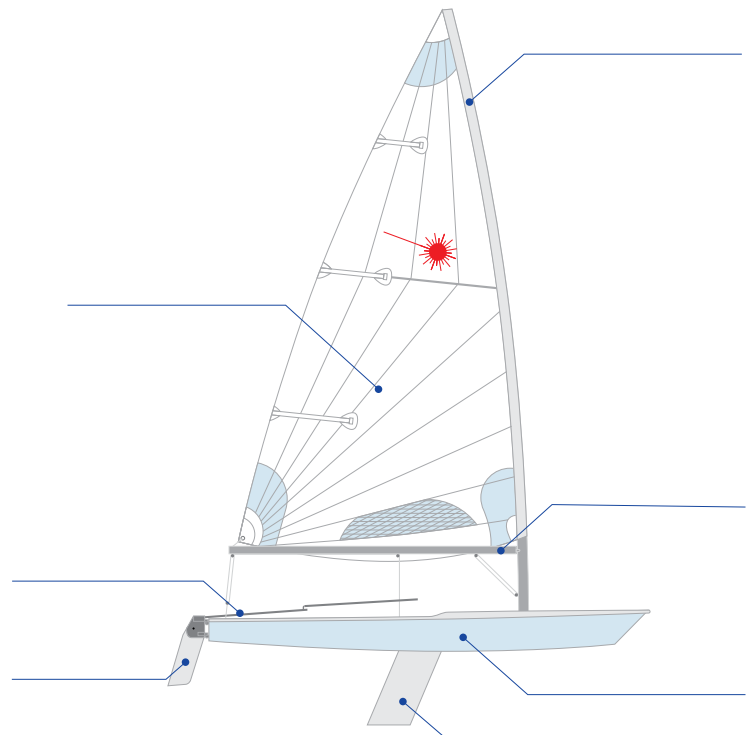

- |           |      |        |             |
|-----------|------|--------|-------------|
| Main sail | Mast | Hull   | Daggerboard |
| Tiller    | Boom | Rudder |             |



## Quiz time!

Let's see what we remember from Topic 1: Race with World Sailing!  
This is a 2 person team quiz. Read each question and decide on the answer with your teammate. Check with your instructor for the answers!

1. When did World Sailing start?

- a. 1905
- b. 1906
- c. 1907

2. What is the name of the goals that aim to solve extreme poverty, combat climate change and fight inequality and injustice?

- a. United Nations Environmental Goals
- b. United Nations Sustainable Development Goals
- c. United Nations Eco-Development Goals

3. Which of the races that you learnt about in Topic 1 is the oldest?

- a. The Ocean Race
- b. The Olympic Games
- c. America's Cup

4. Which of the races that you learnt about in Topic 1 is the longest?

- a. SailGP
- b. The Ocean Race
- c. America's Cup

5. For 1 of the races can you remember 1 fact about sustainability?

---

---

---

6. Which of the boats that you learnt about in Topic 1 is the fastest?

- a. F50
- b. IMOCA 60
- c. VO65

7. How many sailing events are there in the Olympic Games, where you can win a medal?

- a. 5
- b. 10
- c. 14

8. How many times has Dee Caffari single-handedly sailed non-stop around the world?

- a. 1
- b. 2
- c. 3

9. Who does Yago Lange sail with in the Olympic Games?

- a. his father
- b. his sister
- c. his brother

10. List 4 things that make someone a top sailor

---

---

## Debrief time

I'd like to sail a \_\_\_\_\_ because \_\_\_\_\_

I'd like to compete in \_\_\_\_\_ race because \_\_\_\_\_

2 individual skills I need to develop to become a top sailor are:

\_\_\_\_\_ because \_\_\_\_\_

\_\_\_\_\_ because \_\_\_\_\_

I want to become a more sustainable sailor because

---